

INV813Z-RTS

3 Megapixel Vandal Dome Camera with IR

Infinique offers a wide range of IP based high definition cameras from 1.4MP to 6MP which are available in Box, Dome and Bullet housing. Our cameras are equipped with superior image sensor and digital signal processor to produce sharp, crisp pictures and are enclosed in weather-proof vandal resistant housing making it suitable for use in different types of applications. The ONVIF compliance of our cameras helps in easy integration, providing peace of mind for your investment. From small to very large installations, Infinique’s cameras are reliable, future proof and an ideal solution for your video surveillance needs.

The INV813Z-RTS is a 3 Megapixel IR Dome Camera with weather-proof vandal resistant aluminum housing, incorporating a 1/3” high quality image sensor and IR LEDs providing clear crisp images both during the Day and Night.

The camera comes equipped with 2.8~12mm motorized zoom lens for easy setup of field of view. The auto iris control allows the camera to automatically set its iris position to maximize image quality in all lighting conditions. The camera streams real-time video at high definition resolution using H.264 or H.265 compression optimizing the bandwidth and increasing storage efficiency.

Built-in PoE for powering the camera and the flexible 3-axis bracket for fixing it on ceiling or wall, provides the convenience for installers to complete the installation quickly and with ease. These excellent IP cameras are highly suitable for video surveillance of government buildings, residential apartments, schools, colleges, universities, shopping malls, hospitals, hotels, industrial parks, and corporate offices.

Product Features

- 1/3” CMOS Sensor
- 3 Megapixel Resolution at 25/30 fps
- IR LEDs, IR Distance up to 40 meters
- 2.8~12mm Motorized Zoom Lens
- Digital WDR
- S/N Ratio of more than 50dB
- H.265, H.264 Compressions
- Up to 3 Simultaneous Video Streams
- Micro SD Card Slot for Onboard Storage
- Power Over Ethernet (PoE), IEEE 802.3af
- IP66 Rated Weather Proof Housing
- Wall or Ceiling mount with 3 Axis Bracket
- ONVIF Compliant Profile-S



Dimensions

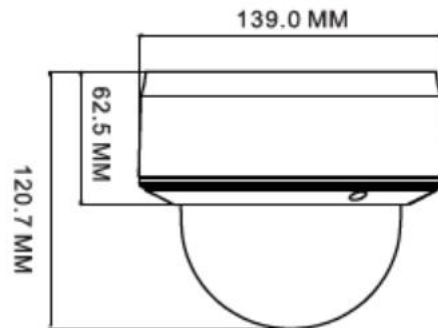

INV813Z-RTS

3 Megapixel Vandal Dome Camera with IR



IMAGE PERFORMANCE		NETWORK	
Image Sensor	1/3" CMOS	Network Port	10/100M BASE-TX, RJ-45 Connector
Effective Pixels (H x V)	2048 x 1536	Cabling Type	Category 6 and higher
Resolution (Megapixels)	3	Network Protocol	IPv4, HTTP, HTTPS, TCP/IP, UDP, RTP, RTSP, RTCP, DNS, DDNS, DHCP, FTP, NTP, PPPOE, SMTP, SNMP, UPNP, IEEE802.1X
Minimum Illumination	0.05 lux (AGC ON) 0 lux with IR ON	ONVIF Protocol	ONVIF Compliant Profile-S
Image Rate (fps)	25 / 30, adjustable for all resolutions	Security	User Access with password protection, IP Filtering
S/N Ratio	More than 50dB	Users	1 Administrator, 6 Users
IR Distance (m)	40	PC Web Browser	IE 6.0 Above; Mozilla Firefox; Google Chrome
LENS		Mobile Device	Windows Mobile, Symbian, iPhone, Android
Focal Length (mm)	2.8~12 Varifocal Motorized Zoom Lens	Events	Motion and Tamper detection
Iris	DC Auto Iris	Event Handlers	FTP, E-mail
Lens Mount	M14	MECHANICAL	
Aperture Ratio	F1.2	Housing ID	V4DIMWH661040S1
Angle of View (deg)	H:108.6 (Wide)~22.4 (Tele), V:81.4 (Wide)~15.8 (Tele)	Dimensions (mm)	139 (D) x 129.7 (H)
VIDEO		Weight (g)	844
Video Compression	H.265 Main Profile H.264 Baseline Profile/Main Profile/High Profile	Housing	Vandal Resistant Aluminum Alloy Housing
Main Stream	2048x1536, 2304x1296, 1920x1080, 1280x960, 1280x720	Finish	White Powder Coat, RAL 9003
Sub Stream	1280x720, 640x480, 320x240 (optional 1920x1080)	Installation	Ceiling Mount / Wall Mount, 3-Axis Bracket
Mobile Stream	640x480, 320x240	ELECTRICAL	
Electronic Shutter Control	1/5 ~ 1/20,000 sec	Power Consumption	580mA, 12V DC, 7W
Day/Night Control	Automatic / Manual	Power Source	PoE IEEE802.3af; DC12V
Flicker Control	50 Hz, 60 Hz	Power Connector	3.5mm Power Jack
Digital WDR	On / Off / Adjustable Level	RTC Backup Battery	3V Magnesium Lithium
3D Noise Reduction	Auto / Manual / Disable	ENVIRONMENTAL	
White Balance	Automatic / Manual / Indoor	Operating Temperature (C)	-10 to +50
Backlight Compensation	On / Off	Storage Temperature (C)	-20 to +60
Automatic Gain Control	Adjustable Level	Operating Humidity	0% - 95% non condensing
Privacy Mask Zones	Up to 4 Privacy Mask Zones	Ingress Protection Rating	IP66
Video Bit rate	256K-8M ,Supports CBR/VBR	STANDARDS COMPLIANCE	
OSD	Camera ID, Timestamp	Emissions	FCC Part 15 Subpart B Class B EN 55022:2010 IC ICES-003 Class B
Image Orientation	Image Flip, Corridor Mode, Rotation	Immunity	EN 55024:2010
Image Controls	Brightness, Contrast, Hue, Saturation, Sharpness	Safety	UL 609501, EU: 2001/95/EC GSPD
Advanced Functions	Image Rotation, Gain Control, Anti-Fog, Anti-False Color, Anti-Shake, IR Detection		
VIDEO ANALYTICS			
Motion Detection	Multiple Zones		
Advance Video Analytics	Tamper, Out Of Focus, Perimeter Intrusion, Line Crossing, Stationary Object, Pedestrian Detection, People Counting, Face Detection		
LOCAL STORAGE			
Storage Type	Micro SD card, Max up to 128GB		
Recording	Video and Image; Auto / Schedule/ Manual / On Event		

ORDERING INFORMATION	
PART NUMBER	DESCRIPTION
INV813Z-RTS	Infinique Premium Series Vandal IR Dome Camera, 1/3 CMOS Sensor, 3MP, 25/30fps, 0 Lux, 2.8-12mm Motorized Zoom Lens, IR LED, 40m IR Range, H.265, H.264, Three Video Streams, True Day and Night with ICR, Adjustable Bit Rate, ONVIF Compliant, SDHC Slot, PoE, IP66

Infinique, a Canadian company is a manufacturer of high performing end-to-end solutions in copper, fiber and video surveillance systems. For more information visit our website at www.infinique.com or email us at sales@infinique.com.